

**INTELLIGENT
DRIVES &
CONTROLS
FOR SHUTTERS
AND AWNINGS**



INSTALLATION & OPERATING INSTRUCTIONS

Instructions and notes for installation and operation

3T-MOTORS® Shutter / Awning motors with mechanical limit switches

Motor type 3T45
(For shafts from 60 mm)

3T45-10
3T45-20
3T45-30
3T45-40
3T45-50

Motor type 3T35
(For shafts from 40 mm)

3T35-10
3T35-13

Attention:

It is important for the safety of persons
to follow these instructions.
Keep these instructions for future reference.



3T-MOTORS® Shutter motors / Awning motors with mechanical limit switches

Guideline / Determine torque	Page 3
! Safety instructions	Page 4
i Function overview	
Scope of delivery	Page 5
Technical data	Page 5
! Installation notes	Page 6
✘ Installation instructions	
Installation shutter motor	Page 7 – 12
• Installation situation	Page 7
• 1) Prepare power connection	Page 7
• 2) Select motor bearing	Page 7 – 8
• 3) Remove shutter shaft	Page 9
• 4) Prepare motor for installation	Page 9
• 5) Mount bearings	Page 9
• 6) Mount motor with shaft unit	Page 9 – 10
• 7) Shutter motor wiring	Page 10
• 8) Setting the end positions	Page 11 – 12
• Mounting instructions for motor type 3T35	Page 13
Installation awning motor	Page 14 – 16
• 1) Preparation	Page 14
• 2) Prepare motor for installation	Page 14
• 3) Mounting awning motor	Page 14 – 15
• 4) Awning motor wiring	Page 15
• 5) Setting the end positions	Page 16
✘ Troubleshooting	
What to do when ...	Page 17
§ EU Declaration of Conformity	Page 18
⊛ Optional accessories tubular motors	Page 19



CONTACT

3T-Components GmbH & Co. KG

Grete-Schickedanz-Str. 5
D-55545 Bad Kreuznach

Email: info@3t-components.de

Tel: +49 (0)671 887 673-0

Fax: +49 (0)671 887 673-99

Opening hours:

Monday – Friday
8.00 – 16.30

Learn more about us:



www.3t-components.de

© Copyright notice

All contents of these instructions, in particular texts, photographs and graphics, are protected by copyright. Unless expressly indicated otherwise, the copyright is held by 3T-Components GmbH & Co. KG. Please ask us if you wish to use the contents of this document.

GUIDELINE

With this guide, you can determine the ideal torque in Newton meters (Nm) for the shutter motor.

DETERMINE WEIGHT ROLLER SHUTTER

1.) Determine roller shutter area

$(\text{Height} + 150 \text{ mm}) \times \text{Width} = \text{Roller shutter area (m}^2\text{)}$

2.) Determine weight roller shutter material

Take approximate weights per m² of roller shutter area from the table.

3.) Determine weight roller shutter

$\text{Roller shutter area (m}^2\text{)} \times \text{weight roller shutter material (m}^2\text{)}$

4.) Calculate required traction force

Friction losses must be taken into account (rail guidance) of approx. 10%!

Material	kg / m ²
PVC	5
Aluminum Light	6
Aluminum Heavy	9
Steel	11
Wood	11

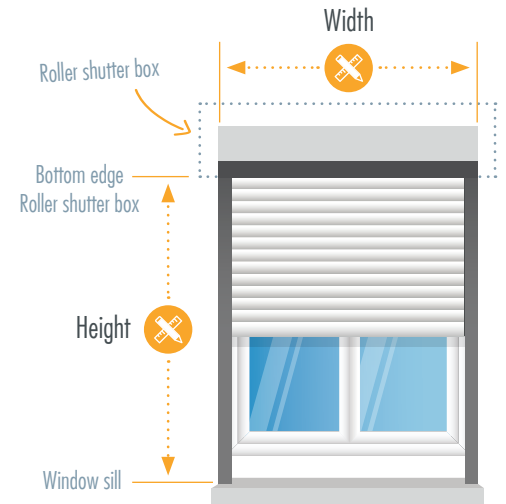

Roller shutter area (m²) x Weight roller shutter material (m²) = Weight roller shutter (kg) + 10% Friction losses = Required traction force (kg)

Example:

PVC-Roller shutter area 3,00 m² x Weight roller shutter material 5 kg = 15 kg Weight roller shutter + 10% Friction losses = 16,5 kg Required traction force

DETERMINE SHUTTER MOTOR TORQUE

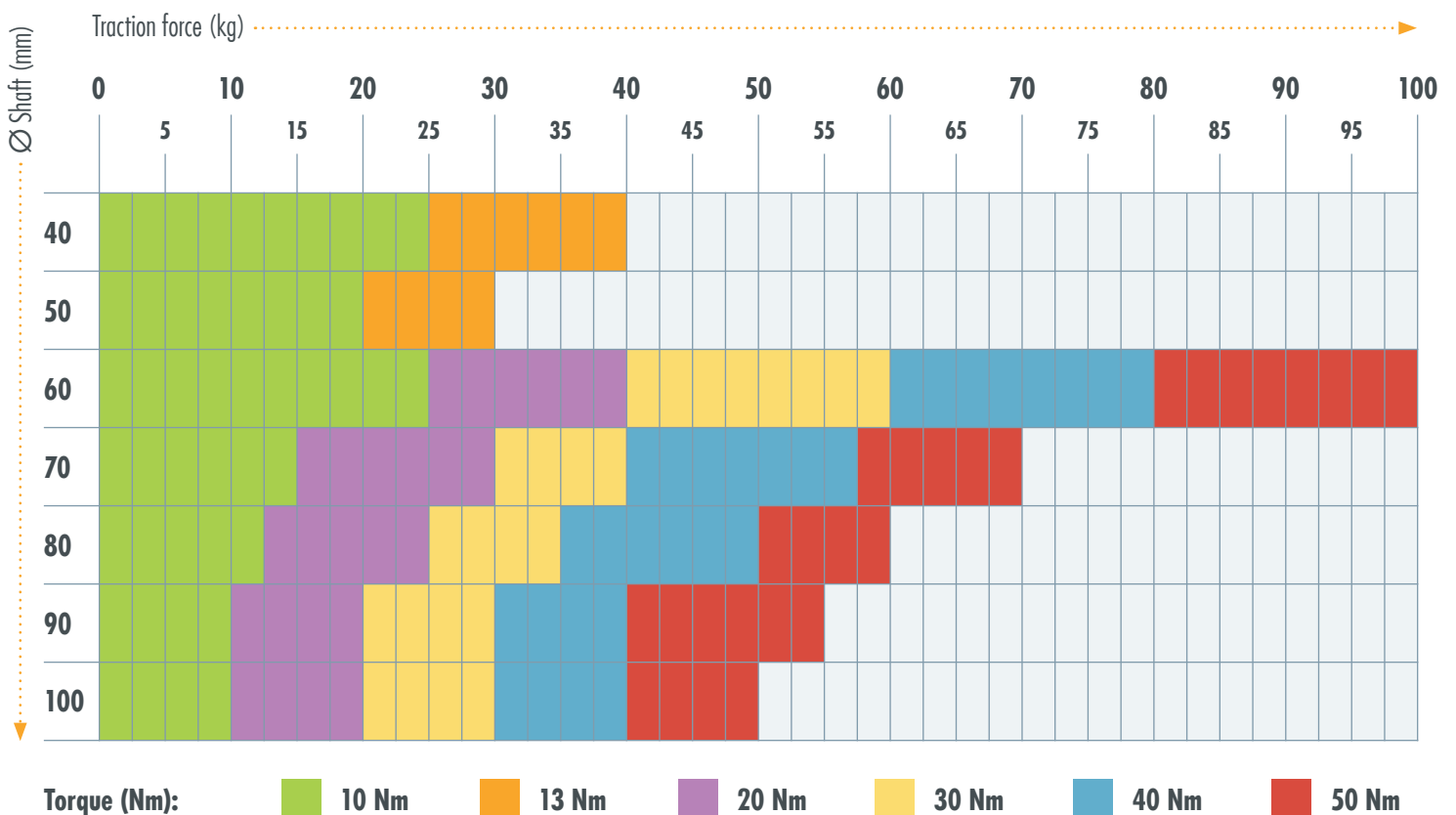

! SAFETY INSTRUCTIONS

Please read these important safety instructions before commissioning!

Incorrect installation can cause serious personal injury and damage to property.

The warranty claim expires in case of non-observance of this user information with all contained notes and regulations.

In case of non-observance of these instructions, the manufacturer or supplier shall not be liable for any personal injury or property damage incurred.



This symbol indicates danger due to electrical energy.
Danger to persons and objects may arise if the associated information is not observed!

GENERAL SAFETY INSTRUCTIONS

- **WARNING:** Important safety instructions.
Follow all instructions as incorrect installation may result in serious injury.
- **WARNING:** The drive must be disconnected from the power source during cleaning, maintenance and replacement of parts.
- Danger to life from electric shock when working on electrical equipment.
- The electrical connection, installation and commissioning of the receiver may only be carried out by qualified personnel.
- Before installing the drive, remove all unnecessary cables and disable all devices, that are not required for operation with power.
- The relevant regulations and guidelines must be followed without fail, to avoid damage to persons and objects.
- Observe safety instructions according to EN 60 335-2-97: The power supply cable of the drives must be laid internally.
- Installation according to DIN 18073: The roller shutter box cover must be easily accessible and removable.
- Installation according to EN 60335: Only switches / pushbuttons / switching devices with a minimum contact opening of 3 mm may be used, furthermore the up and down direction must be interlocked against each other.
- When installing in damp rooms, observe regulations (VDE 0100, part 701 and 702).
- Please never operate several motors via one switch / pushbutton, unless you are using cut-off relays or other controls that allow parallel operation.
- Do not use defective devices: Never use defective equipment.
Periodically inspect the equipment for imbalance and signs of wear or damage to cables and suspension springs.
Do not use equipment if repair or touch-up is necessary.
There is a risk of personal injury and property damage due to electric shock or short circuit.
- Retain the instructions for future reference.



This symbol indicates information about general danger.
Non-observance can mean danger to persons and objects!

IMPROPER USE

- Persons are to be instructed with the correct operation of the tubular motor.
- The roller shutter movement must be monitored in order not to endanger persons.
- Do not allow children to play with motor controls.
- Store the handheld transmitter in such a way that unintentional operation is prevented (e.g. by children playing).
- The device can be used by children aged 8 years and above and persons with reduced physical, sensory or mental capabilities or lack of experience and knowledge, if they have been given supervision and instruction concerning use of the appliance in a safe way and are aware of the hazards involved.
- Children are not allowed to play with the equipment.
- If the power supply cord of this device is damaged, it must be replaced by the manufacturer or its customer service or a similarly qualified person to prevent hazards.



This symbol indicates important information that can ensure safe and proper use of the device.

PROPER USE

- Use tubular motors only for automating shutters.
- Only use original components and original accessories from the manufacturer.
- The mains connection cable of the drives must be laid internally in the empty conduit up to the junction box.
The local electrical regulations must be observed.
- For the electrical connection of the tubular motors, a 230 V / 50 Hz power connection with fuse must be available at the installation site.
- Inspect the installation frequently for imbalance and signs of wear or damage to cables and springs.
Do not use if repairs or adjustments are required.

i FUNCTION OVERVIEW

SCOPE OF DELIVERY – MOTOR TYPE 3T45

- 1 Motor
- 2 Limit switch adapter
- 3 Shaft adapter
- 4 Connection cable 3 meters
- 5 Adjustment pin
- 6 Universal bearing & cotter pin
- 7 Cover cap bearing
- 8 Securing bracket
- 9 Manual

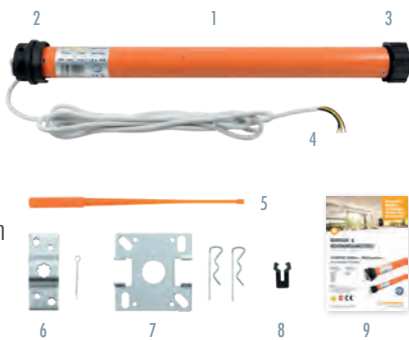

SCOPE OF DELIVERY – MOTOR TYPE 3T35

- 1 Motor
- 2 Limit switch adapter
- 3 Shaft adapter
- 4 Connection cable 3 meters
- 5 Adjustment pin
- 6 Universal bearing & cotter pin
- 7 Clip bearing
- 8 Securing bracket
- 9 Manual



Technical data

Optional adapter sets + accessories > Optional accessories tubular motors (Page 19)

Motor type	3T45-10	3T45-20	3T45-30	3T45-40	3T45-50	3T35-10	3T35-13
Torque (Nm)	10 Nm	20 Nm	30 Nm	40 Nm	50 Nm	10 Nm	13 Nm
Traction power (kg)	25 kg	40 kg	60 kg	80 kg	100 kg	25 kg	40 kg
Max. PVC shutter area (m ²)	4,5 m ²	6 m ²	9 m ²	11 m ²	15 m ²	5,25 m ²	7 m ²
Max. ALU shutter area (m ²)	3,0 m ²	4,7 m ²	7 m ²	9,5 m ²	12 m ²	4,2 m ²	5,5 m ²
Power (W)	112 W	145 W	191 W	198 W	205 W	121 W	121 W
Turn Speed (U/min)	15 U/min	15 U/min	15 U/min	15 U/min	12 U/min	17 U/min	14 U/min
Limit switch capacity (min)	22 U	22 U	22 U	22 U	22 U	30 U	30 U
Operating voltage (V AC)	230 V	230 V	230 V	230 V	230 V	230 V	230 V
L1 Total motor length (mm)	474 mm	474 mm	545 mm	545 mm	545 mm	474 mm	474 mm
L2 Installation length (mm)	449 mm	449 mm	525 mm	525 mm	525 mm	454 mm	454 mm
Connection line (m)	3 m	3 m	3 m	3 m	3 m	3 m	3 m
Max. Runtime (min)	4 min	4 min	4 min	4 min	4 min	4 min	4 min
Protection class	IP44	IP44	IP44	IP44	IP44	IP44	IP44
EAN	4260336110514	4260336110811	4260336110040	4260336110057	4260336110064	4260336110002	4260336110019

Emission sound pressure level LpA ≤ 70 dB(A)

! INSTALLATION NOTES



Before installation, all non-essential electrical wiring must be removed, all mechanisms that are not necessary for motorized operation must be deactivated.

- Do not expose the tubular motor to crushing, impact, falling or contact with any liquids. Do not punch holes in the entire length of the tube (motor casing) or attach screws to it.



- Please use suitable suspension springs to fasten the roller shutter curtain to the roller shutter shaft. You will find suitable suspension springs on page 19 and in our store under mounting accessories.



- Important for motor type 3T35 (SW40):

It is essential to use mini suspension springs for motor operation. These special mini springs protrude only approx. 1 mm into the shaft. This allows the shaft to rotate freely. When using commercially available suspension springs the motor housing is left with grinding marks because the suspension pin protrudes too far into the roller shutter shaft, which leads to damage and destruction of the motor.

Mini suspension springs (Page 19)

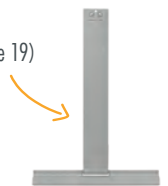

- For steel shafts with a width across flats of 40 mm (SW40), only use shafts with an external fold. Steel shafts with an internal fold will damage and destroy the motor.



Do not use 8-sided shaft SW40 with internal fold!



8-sided shaft SW40 with external fold

- Grinding marks of any kind on the motor housing will void the warranty.



- The inspection cover of the roller shutter box must be easily accessible and removable.

- We recommend using a tubular motor with a power 10% higher than the weight of the shutter, to compensate for the frictional resistance of the rail guide. > See Guideline / Determine torque (page 3)

- The motor is designed for short-time operation (4 min). It has an internal thermal circuit breaker which interrupts the power supply in the event of overheating, e.g. as a result of continuous operation. The cooling phase is min. 10 min, the thermal switch resets automatically. Regular operation is only possible after the the motor has cooled down completely.

INSTALLATION INSTRUCTIONS



Please note:

- The motor can be installed on the right-hand side as well as on the left-hand side. If the direction of rotation is reversed, please exchange the wires for the up and down direction.
- The setting of the end positions is only possible in the installed state (motor in shutter shaft).
- Never place screws in the area of the tube motor, as they will damage the motor.
- **Engine damage caused by improper use or unprofessional installation, lead directly to loss of warranty.**

INSTALLATION SHUTTER MOTOR

Installation situation

- 1 Counter bearing*
- 2 Ball bearing*
- 3 Roller capsule*
- 4 Shutter shaft*
- 5 Suspension spring*
- 6 Shaft adapter
- 7 Tubular motor
- 8 Limit switch adapter
- 10 Limit switches
- 10 Engine mount
- 11 Shutter curtain*

* Accessories; not included

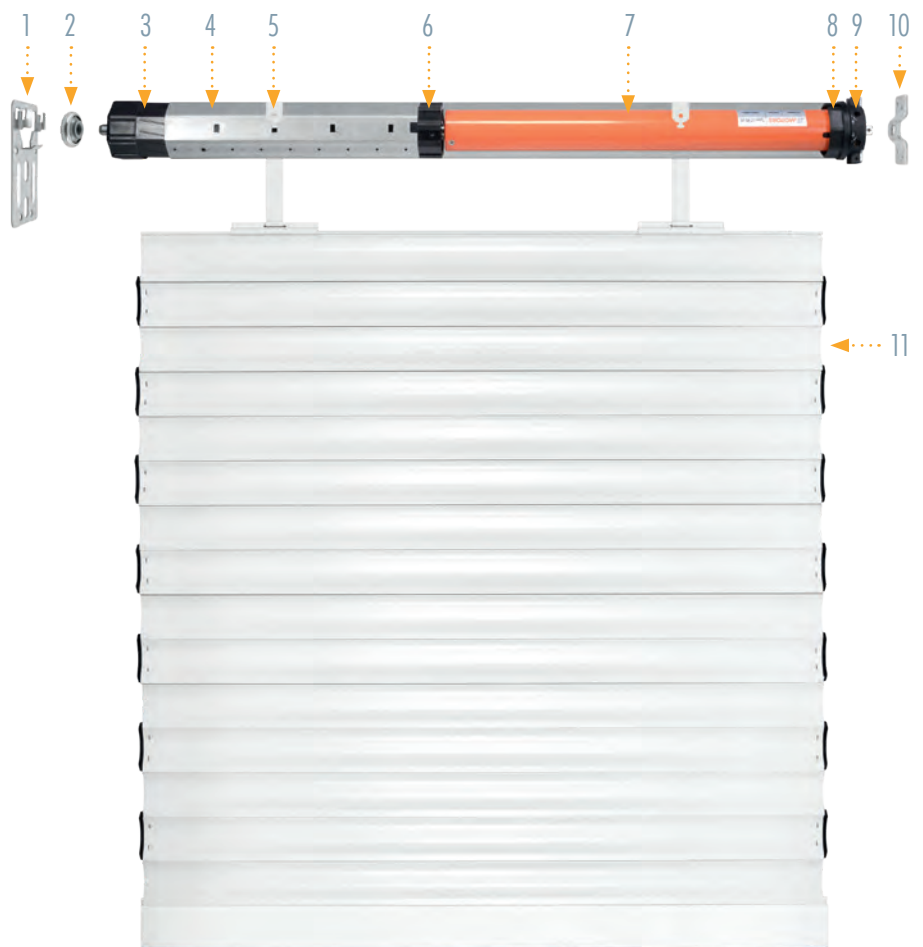

1 Prepare power connection:

- The mains connection cable of the drive must be laid internally in the empty conduit up to the junction box. The local electrical regulations must be observed.

2 Select motor bearing:

- Two motor bearings are supplied with motor type 3T45 and 3T35: Universal bearing (3T45/3T35) and cover cap bearing (3T45) / clip bearing (3T35).
- Use one of the two motor bearings depending on the installation situation.

INSTALLATION INSTRUCTIONS

Motor type 3T45

Installation with universal bearing or cover cap bearing

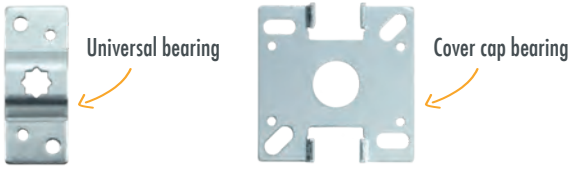

Installation with universal bearing:

- Push the motor with the square into the opening of the bearing and secure with safety pin.

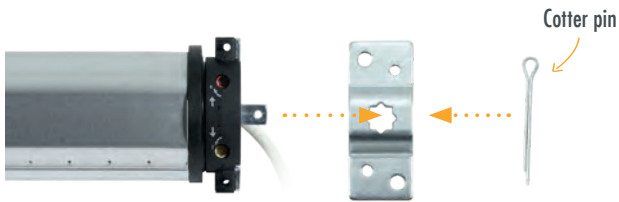

Installation with cover cap bearing:

- Remove screws from metal plate on motor head > fig. 2.1
- Remove metal plate > fig. 2.2
- Remove motor square spigot > fig. 2.3
- Reattach metal plate > fig. 2.4

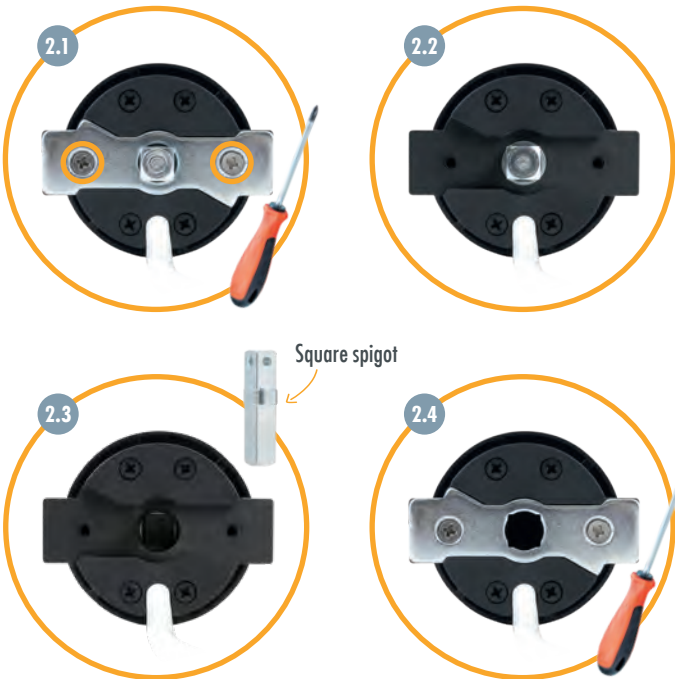

- Slide motor type 3T45 without square spigot into cover cap bearing and secure with both securing clips.



Motor type 3T35

Installation with universal bearing or clip bearing

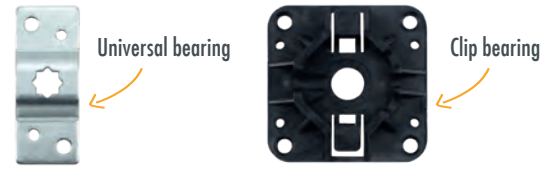

Installation with universal bearing:

- Push the motor with the square into the opening of the bearing and secure with cotter pin.

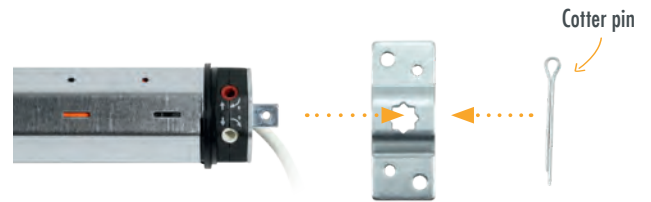

Installation with clip bearing:

- Remove screws from metal plate on motor head > fig. 2.5
- Remove metal plate > fig. 2.6
- Remove motor square spigot > fig. 2.7
- Reattach metal plate > fig. 2.8

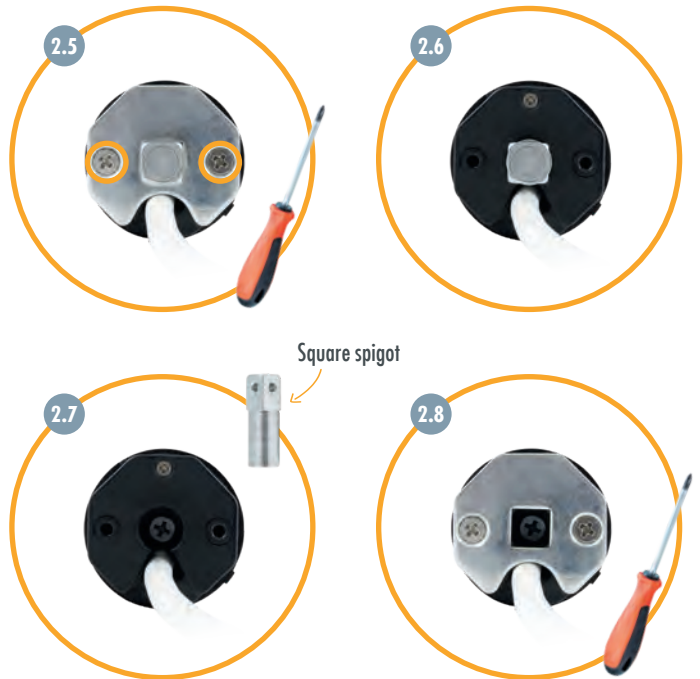

- Engage motor type 3T35 without square spigot in clip bearing.



INSTALLATION INSTRUCTIONS

3 Remove shutter shaft:

- Lower the roller shutter.
- Open the cover of the roller shutter box.
- Release the suspension springs from the roller shutter shaft.
- Lift roller shutter shaft incl. ball bearing out of the holder.

4 Prepare motor for installation:

- Push limit switch adapter flush against motor head. > fig. 4.1 / 4.2
- Secure the shaft adapter with the supplied securing bracket. > fig. 4.3 / 4.4
- Push the motor into the roller shutter shaft without using force (never knock it in). The fold of the shaft must lie over the recess in the shaft adapter. > fig. 4.5 / 4.6
- Make sure that the roller shutter shaft is flush with the motor head limit switch adapter. > fig. 4.7 / 4.8



5 Mount bearings:

- Remove old wall bearing on motor side (left or right installation possible).
- Mount motor bearing at this point (2 mounting options: Universal bearing and cover cap bearing / clip bearing).
- Please mount the bearings so that the limit switches are freely accessible.
- Make sure that the roller shutter motor with the shaft unit sits horizontally in the roller shutter box.



6 Mount motor with shaft unit:

- Insert the motor head (with the entire shaft unit) into the motor bearing and secure it with the supplied cotter pin or securing clips (Cover cap bearing).

✂ INSTALLATION INSTRUCTIONS

- On the opposite side of the motor, push the roller capsule out of the roller shutter shaft until it fits into the ball bearing inserted in the wall bearing.
- Fix roller capsule to roller shutter shaft with self-tapping screw. Position the screw at a punched hole. This prevents the screw from slipping.

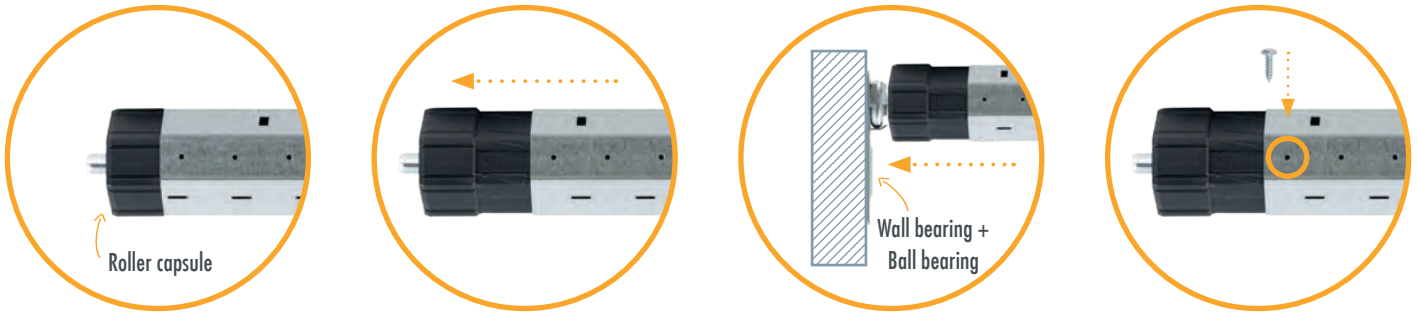

7 Shutter motor wiring:

- Connect the roller shutter motor and switch (or timer) to the mains.
- The electrical connection of the roller shutter motor and control unit may only be carried out by qualified personnel.
- If the drive should run in the opposite direction after installation, the motor's upstream and downstream leads (brown + black) must be turned.

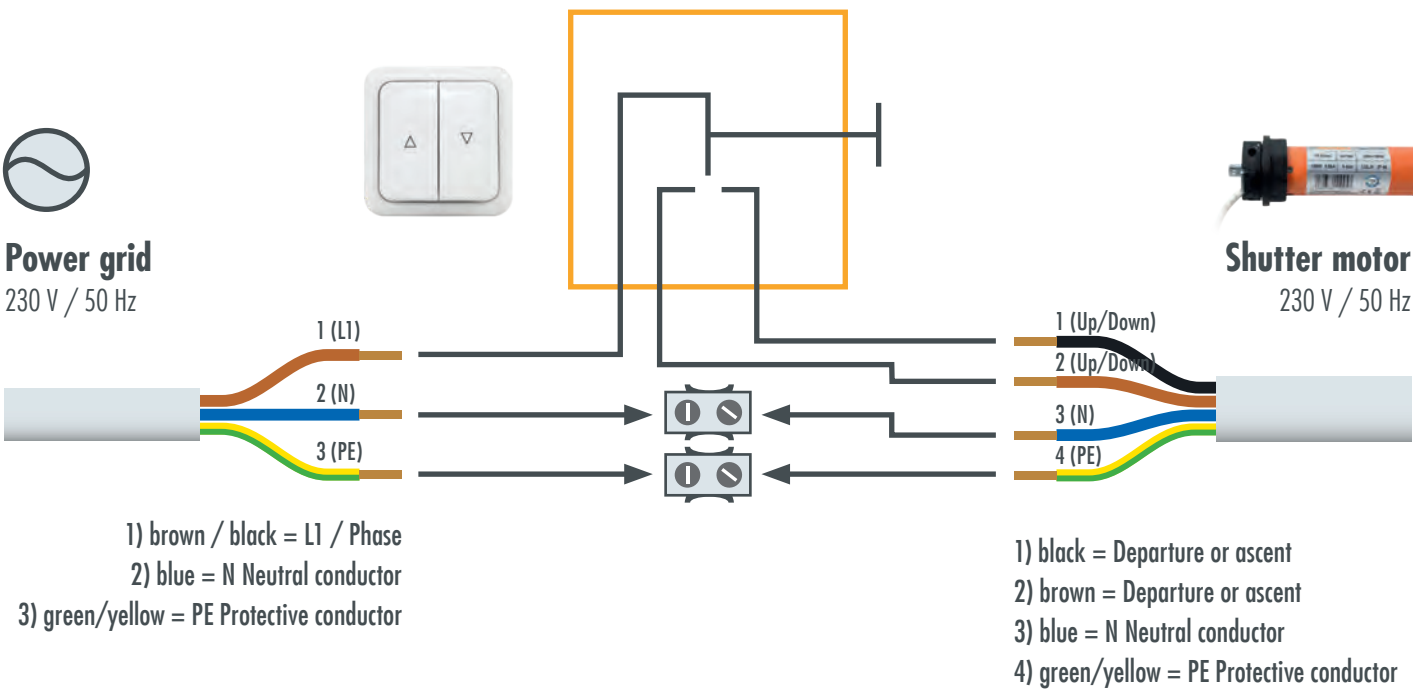

The connection diagram of time switches differs from this circuit diagram!
Please refer to the corresponding manual for the connection diagram.

✂ INSTALLATION INSTRUCTIONS

8 Setting the end positions:

Explanation of the limit switch screws

There are 2 limit switch screws on the motor head. One limit switch screw is responsible for the upper end position, the other for the lower end position. The end positions can be adjusted by turning the limit switch screws with the adjustment pin.

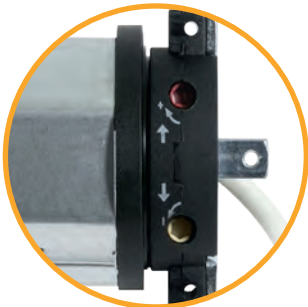

Motor type 3T45 / Power cable to rear

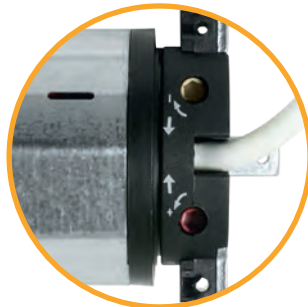

Motor type 3T45 / Power cable to front

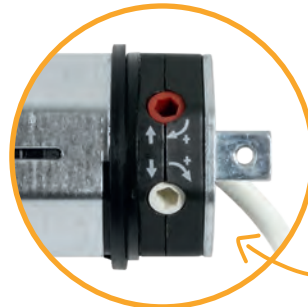

Motor type 3T35 / Power cable to rear

Adjustment pin

On 3T35 motor types, the limit switch screws are located on one side of the motor head only.

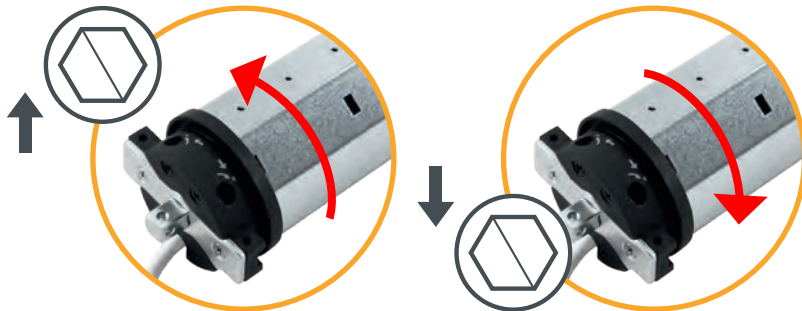

The straight up and down arrows indicate the direction of rotation of the motor and shaft and thus show you for which end position the limit switch screw next to it is responsible. Depending on whether the direction of rotation leads to unrolling or rolling up of the roller shutter, the limit switch screw is responsible for the lower or upper end position (unrolling > lower end position, rolling up > upper end position).



The arrows with PLUS and MINUS apply to both limit switch screws and show you in which direction you must turn the adjusting pin to switch off the motor sooner or later. Turning the limit switch screw in the PLUS direction after switching off allows the motor to continue moving step by step in the corresponding direction. Turning the limit switch screw in the MINUS direction during travel causes the motor to switch off earlier. For motor type 3T45 / power cable to the front, the PLUS and MINUS directions change (see marking on the motor head).

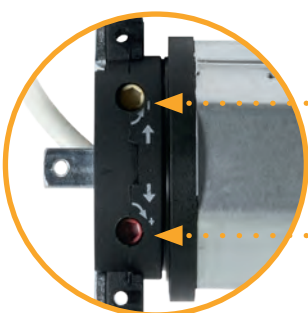

Left installation

- Limit switch screw white: Lower end position
- Limit switch screw red: Upper end position

Power cable to rear

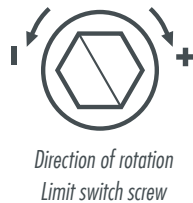

Right installation

- Limit switch screw red: Lower end position
- Limit switch screw white: Upper end position

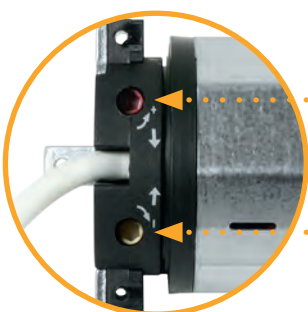
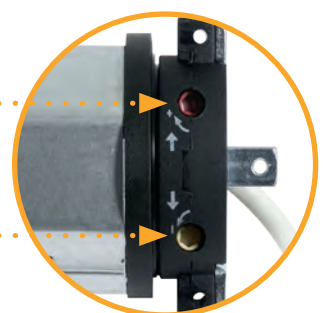

Left installation

- Limit switch screw red: Upper end position
- Limit switch screw white: Lower end position

Power cable to front

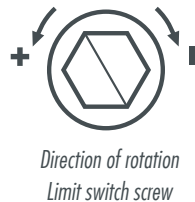

Right installation

- Limit switch screw white: Upper end position
- Limit switch screw red: Lower end position

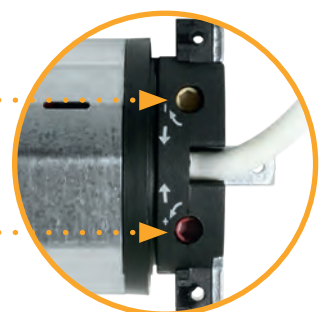

INSTALLATION INSTRUCTIONS

Special case: Roller shutter rolls down in front of motor + shaft

If the roller shutter curtain rolls in front of the motor and shaft, the responsibilities of the limit switch screws for the upper and lower end positions are reversed. See illustration of left-right installation on page 11: upper end position > lower end position / lower end position > upper end position.

1. Setting the lower end position

- Do not fasten the roller shutter curtain!
Detach all suspension springs from the roller shutter shaft!
- Move the motor + shaft in the downward direction until the lower limit switch-off occurs automatically and the motor stops.
- Move motor + shaft upwards.
While the motor is moving upwards, turn the adjustment pin on the limit switch screw for the upper limit position in the MINUS direction (up to 100 turns, depending on the motor type) until the motor switches off after approx. 4 turns.
This prevents the roller shutter from being pulled out of the guide rails when the upper end position is set.
- Move motor + shaft in downward direction to the lower end position until the motor stops automatically.
- If the shaft has to be turned a little to hook in the suspension springs, use the adjustment pin on the limit switch screw for the lower end position in the PLUS direction. This causes the motor to turn the shaft stepwise. The rectangular openings in the shaft for hooking in the suspension springs should point forward and be easily accessible.
- Hang the roller shutter curtain on the roller shutter shaft using the suspension springs.

2. Setting the upper end position

- Allow the motor + roller shutter to move upwards until the motor stops automatically at the previously set upper end position.
- To set the upper end position, turn the adjustment pin on the limit switch screw for the upper end position in the PLUS direction to raise the motor + roller shutter further. The upper end position should be that the roller shutter stops approx. 3 cm before the roller shutter box. Reason is the expansion of the roller shutter due to the temperature difference in summer and winter.
- After setting the end positions, lower and raise the motor + shutter to check the set end positions.

Adjustment pin
is required



Note heat generation

The end position setting without shutter curtain load leads to more heat generation in the motor. This is normal behavior and does not result in damage to the motor. If the motor heats up too much, the thermal protection switch of the motor is automatically triggered. After a cooling phase of at least 10 minutes, the motor is ready for operation again.

INSTALLATION INSTRUCTIONS

MOUNTING INSTRUCTIONS FOR 3T-MOTORS® MINI-TUBE MOTORS MOTOR TYPE 3T35



Use proper suspension springs:

- To fasten the roller shutter curtain to the roller shutter shaft, please be sure to use suitable suspension springs for motor operation. These special mini suspension springs only protrude approx. 1 mm into the shaft. This allows the shaft to rotate freely. When commercially springs are used, there will be grinding marks on the motor housing because the suspension pin protrudes too far into the roller shutter shaft, which leads to damage and destruction of the motor. In case of any kind of grinding marks on the motor housing, the warranty claim is void.



- Mini suspension springs > Optional tubular motor accessories (page 19)



Suspension spring

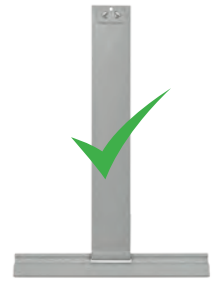

Mini Suspension spring

Use correct roller shutter shaft with external fold:

- For steel shafts with a width across flats of 40 mm (SW40), only use shafts with an external fold. Steel shafts with an internal fold will damage and destroy the motor.



Do not use
8-sided shaft SW40
with internal fold!



8-sided shaft SW40
with external fold



Explanation:

- Avoid overstressing and resulting premature aging of the motor by using the correct suspension springs and the correct roller shutter shaft with external fold!
- Keep in mind that the motor housing has a diameter of 35 mm and the roller shutter shaft SW40 has an outer diameter of 40 mm. When using commercially available springs or roller shutter shafts with internal fold, the motor housing will be left with grinding marks, since the suspension pin or the fold protrude too far into the roller shutter shaft. Contrary to its intended use, the motor runs permanently against an overload and outside its characteristic data.
- Matching roller shutter shafts SW40 > Optional tubular motor accessories (page 19)

INSTALLATION INSTRUCTIONS

INSTALLATION AWNING MOTOR

1 Preparation:

- Screw in awning & secure with straps or ropes.
- Remove awning from wall bracket & place on safe surface.



Attention:

Awning arms are under strong tension!

2 Prepare motor for installation:

- Slide limit switch adapter flush against motor head. > fig. 2.1 / 2.2
- Secure the shaft adapter with the supplied securing bracket. > fig. 2.3 / 2.4

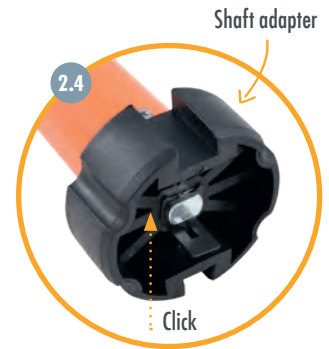
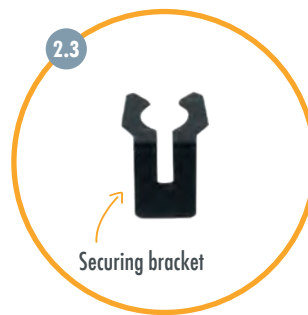
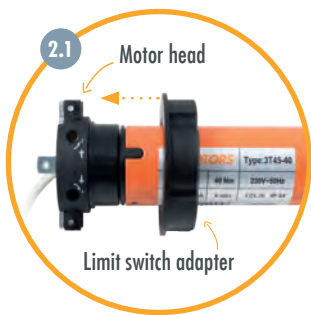

3 Installation awning motor:

- Remove the cover to access the side bearing (also awning bracket) and fastening screws. > fig. 3.1
- Loosen the screw that secures the side bearing to the support tube. > fig. 3.2
- Remove all screws connecting the side bearing and the crank mechanism. > fig. 3.3
- Remove the side bearing from the support tube. > fig. 3.4
- Remove the crank mechanism. > fig. 3.5

- Remove the shaft capsule from the shaft. > fig. 3.6
If the shaft capsule is tight, use a hammer and screwdriver. Be careful not to damage the shaft.
- Push the awning motor with shaft adapter first into the shaft. > fig. 3.7
- Make sure motor head & limit switch adapter are flush in shaft.
- Screw the universal bearing onto the side bearing on the side facing the awning shaft. > fig. 3.8

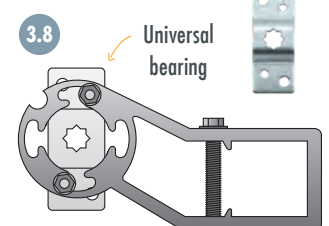
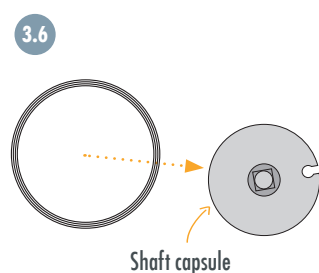
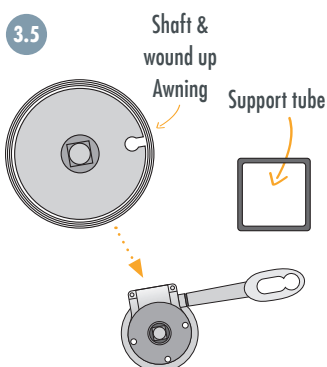
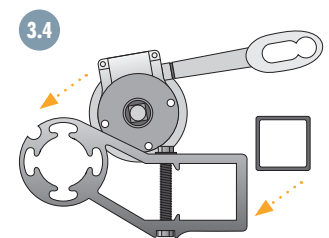
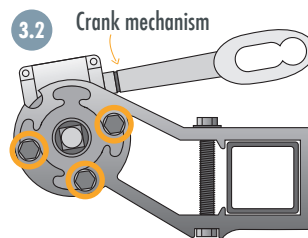
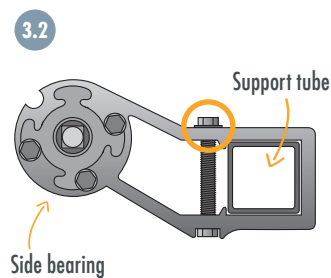
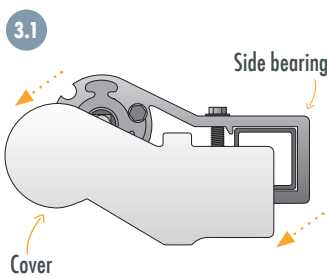

INSTALLATION INSTRUCTIONS

- Slide the side bearing with universal bearing onto the support tube & fasten. > fig. 3.9
- Ensure that the motor square spigot is properly engaged in the universal bearing. > fig. 3.10
- Secure the motor square spigot with the supplied cotter pin. > fig. 3.11
- Attach the cover to the side bearing. > fig. 3.12
- Install awning & release fuses.

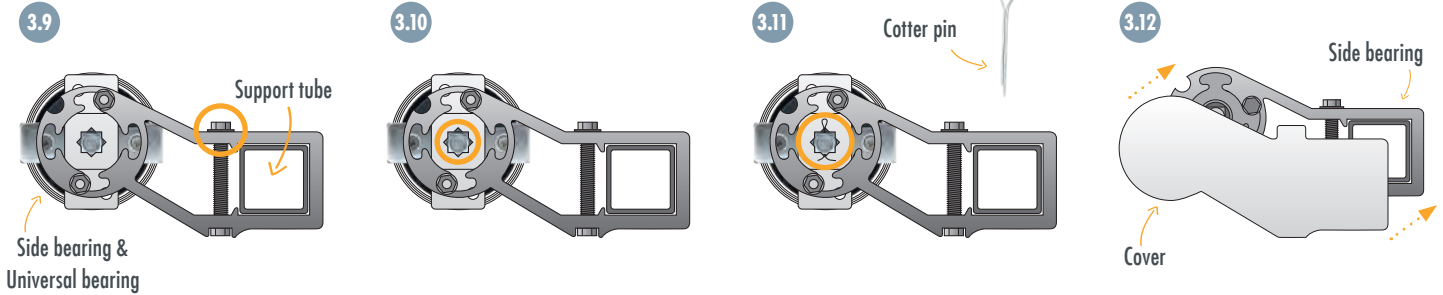

4 Awning motor wiring:

- Connect the awning motor and switch (or timer) to the mains.
- The electrical connection of the awning motor and control may only be carried out by qualified personnel.
- If the drive should run in the opposite direction after installation, the motor's upstream and downstream leads (brown + black) must be turned.

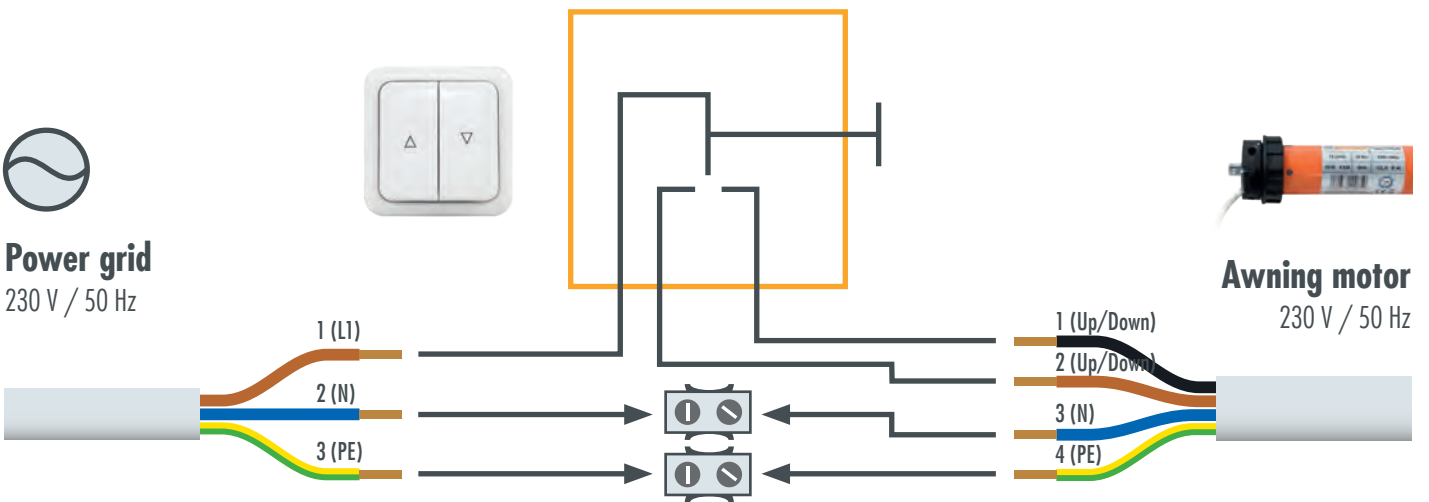

- 1) brown / black = L1 / Phase
 2) blue = N Neutral conductor
 3) green/yellow = PE Protective conductor

- 1) black = Departure or ascent
 2) brown = Departure or ascent
 3) blue = N Neutral conductor
 4) green/yellow = PE Protective conductor

INSTALLATION INSTRUCTIONS

5 Setting the end positions:

Explanation of the limit switch screws

There are 2 limit switch screws on the motor head. One limit switch screw is responsible for the „EXTEND” position, the other for the „RETURN” position. By turning the limit switch screws with the adjustment pin, the positions of the limit switch can be adjusted. A detailed description of the limit switch screws and the markings on the motor head can be found on page 11.

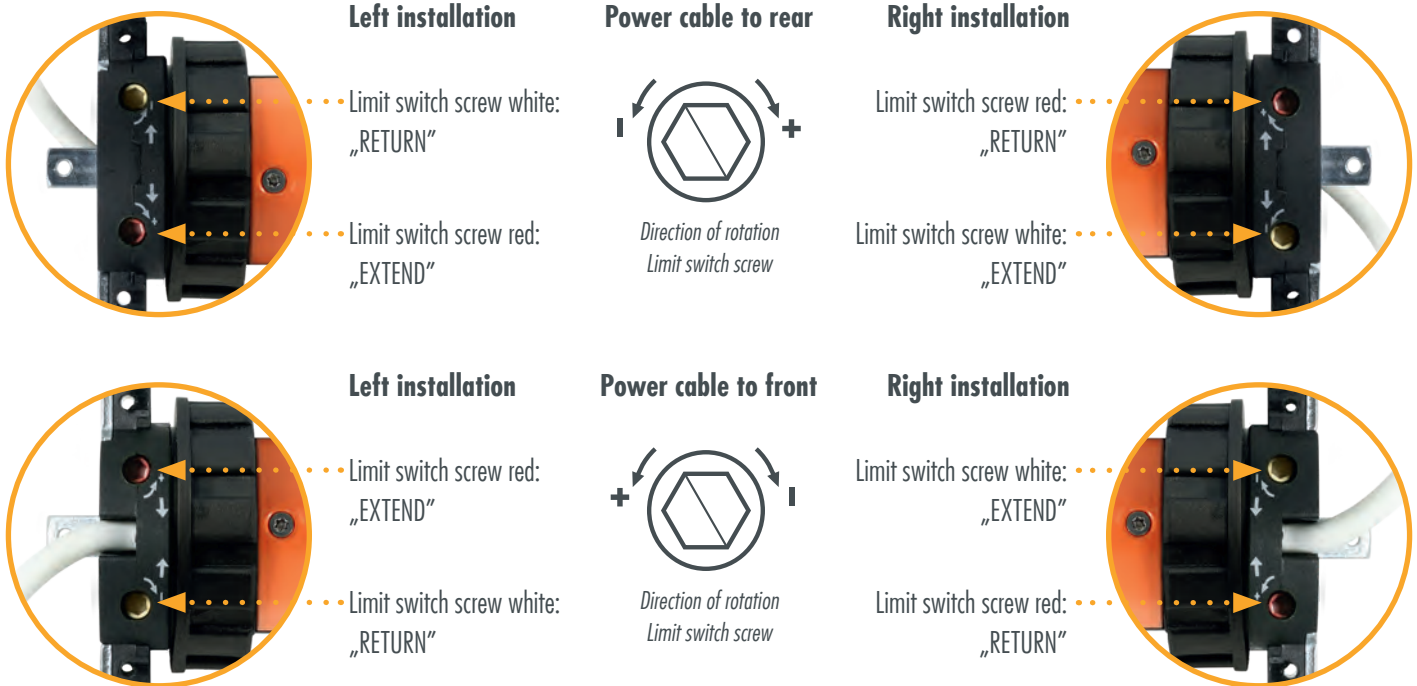

1. Setting the position „EXTEND”

- Set the switch to „EXTEND”, awning moves OUT.
- Run the tubular motor in the „EXTEND” direction until the end switch-off occurs.
- If the motor is to continue moving, turn the adjustment pin on the „EXTEND” limit switch screw in the PLUS direction until the desired position is reached.

2. Setting the position „RETURN”

- Set the switch to „RETURN”, awning moves IN.
- Run the tubular motor in the „RETURN” direction until the end switch-off occurs.
- If the motor is to continue moving, turn the adjustment pin on the „RETURN” limit switch screw in the PLUS direction until the desired position is reached and the awning is fully retracted.

If the awning motor travels too far:

- While the tubular motor is moving in the relevant direction (EXTENDING or RETURNING), turn the adjusting pin on the relevant limit switch screw in the MINUS direction until the tubular motor switches off. If this is not possible, stop with the switch.
- After switching off by turning the limit switch screw in the PLUS direction, allow the tube motor to move to the desired end position.
- If this does not work, run the tube motor again in the opposite direction, stop and repeat this procedure.

 Adjustment pin is required

TROUBLESHOOTING

WHAT TO DO WHEN ...

... the motor does not run?

- Mains voltage is missing.
 - Check correct connection of the control (switch or timer).
-

... the motor is running in the wrong direction?

- Swap the two wires for the direction of rotation (brown + black).
-

... the motor does not switch off at the set point?

- Check fit of limit switch adapter (must be flush with motor head and shutter shaft).
 - Roller capsule is not fixed or roller shutter shaft is too short.
 - Set limit switch screw correctly (see instructions):
MINUS turning during travel shortens the travel distance; PLUS turning after switch-off extends the travel distance.
-

... the motor does not switch off at all?

- Engine was run in removed state (limit switches only work in installed state).
 - Check fit of limit switch adapter (must be flush with motor head and shutter shaft).
 - Limit switches are too far apart:
 - Determine limit switch screws according to explanation on page 11.
 - Do not fasten roller shutter armor!
 - Only allow the shutter shaft to be rotated by the motor.
 - While driving, turn the relevant limit switch screw in the MINUS direction (up to 100 turns depending on the motor type) until the motor switches off.
 - Then allow the roller shutter shaft to rotate in the opposite direction and turn the other limit switch screw in the MINUS direction until the motor switches off.
 - Repeat the entire process (Drive up turn MINUS / Drive down turn MINUS) until the motor switches off in both directions after 2 - 3 rotations.
 - Then allow the roller shutter shaft to rotate downwards until the limit switch is switched off. After switching off, if necessary, continue to move the motor by turning the relevant limit switch screw PLUS to position the holes for the suspension springs.
-

... the motor stops running after continuous operation?

- The thermal protection switch of the motor has tripped. After a cooling phase (min. 10 min.), the motor is ready for operation again.
-

... the motor turns in only one direction?

- Check correct connection of the control (switch or timer).
 - Check the setting of the limit switches.
-

... the motor does not operate at the specified speed?

- Check roller shutter weight; if necessary, correct inclined installation of roller shutter shaft or Eliminate mechanical friction in the roller shutter box or rail guide.

EU Konformitätserklärung

Wir, die Firma

3T Components GmbH & Co. KG
Grete-Schickedanz-Str. 5
55545 Bad Kreuznach
Deutschland

erklären in alleiniger Verantwortung, dass das weiter unten genannte Produkt

Geräteart: Rohrmotor mit mechanischen Endschaltern

Modell Artikelnummer

3T35-10	344
3T35-13	345
3T45-10	346
3T45-20	348
3T45-30	349
3T45-40	350
3T45-50	351

die grundlegenden Anforderungen der aufgeführten EG/EU-Richtlinien erfüllt:

Maschinenrichtlinie	2006/42/EG
EMV-Richtlinie	2014/30/EU
RoHS-Richtlinie	2011/65/EU / Delegierte Richtlinie (EU) 2015/863
WEEE-Richtlinie	2012/19/EU

angewandte Standards und Verordnungen:

EN 60335-1:2012/A13:2017
EN 60335-2-97:2006/A12:2015
EN 55014-1:2017
EN 55014-2:2015
EN 61000-3-2:2014
EN 61000-3-3:2013

Bevollmächtigter zur Zusammenstellung der technischen Unterlagen:

Name, Position: Patrick El Hadj-Henni, Geschäftsführer

Wallertheim, 02.04.2018
.....
Datum

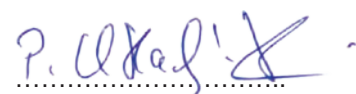
.....
Unterschrift

OPTIONAL ACCESSORIES TUBULAR MOTORS

ANTI-LIFT DEVICE | SHUTTER SHAFTS | ROLLER CAPSULE | SUSPENSION SPRINGS | BALL BEARINGS

OCTOCLICK Anti-lift device 2-link / 2,5-link

- Burglar-resistant
- The pushing up of a closed motorized roller shutter is prevented
- For tubular motors with electronic or mechanical limit switching
- For 50 mm (SW50) and 60 mm (SW60) octagonal shafts
- For roller shutter armor with thickness 8 mm + 14 mm (mounting profile can be rotated)
- Made of glass fiber reinforced polyamide
- No tooling required



Shutter shafts SW60 / SW40

8-sided steel shafts / shaft sets

- SW60 (diameter: 60 mm) up to roller shutter box width: 110 cm / 150 cm / 190 cm / 270 cm / 310 cm / 350 cm
- SW40 (diameter: 40 mm) up to roller shutter box width: 110 cm / 140 cm / 160 cm



Roller capsule long SW60

High quality product

- Length: 140 mm
- Length Steel pin: 12 mm
- PVC



Roller capsule long SW40

High quality product

- Length: 80 mm
- Length Steel pin: 9,8 mm
- PVC



Suspension spring Maxi

Required when using roller shutter motors

- Maxi spring up to 65 mm profile height
- For roller shutter shaft SW60
- Powder coated
- Anti-burglary effect
- Pick up width: 100 mm
- Total length: 215 mm



Suspension spring Mini

Required when using roller shutter motors

- For roller shutter shaft SW40
- Powder coated
- Anti-burglary effect
- Pick up width: 100 mm
- Total length: 140 mm



Ball bearing Maxi

Maxi ball bearing for use in roller shutter bearing

- Outer diameter: 40 mm
- Inner diameter: 12 mm
- Specialized trade quality



Ball bearing Mini

Mini ball bearing for use in roller shutter bearing

- Outer diameter: 28 mm
- Inner diameter: 10 mm
- Specialized trade quality



INTELLIGENT DRIVES & CONTROLS FOR SHUTTERS AND AWNINGS

*Service and
Quality
make the
difference!*



Social Media Links

Info, news and tips on roller shutters, awnings, smart home and more:

www.facebook.com/3TComponents



bit.ly/youtube-3TComponents



www.instagram.com/3tcomponents



twitter.com/3TComponents



3T-Components GmbH & Co. KG

Grete-Schickedanz-Straße 5
D-55545 Bad Kreuznach

Email: info@3t-components.de

Tel: +49 (0)671 887 673-0

Fax: +49 (0)671 887 673-99

www.3t-components.de

Opening hours:

Monday – Friday / 8.00 – 16.30

3T-COMPONENTS
GmbH & Co. KG